

## Flange Nyloc Insert Nut

**Thread Type:** Metric - Fine

**Thread Direction:** Right Hand

**Material:** Carbon Steel

**Class Grade:** High Tensile Class 10

**Finish:** Zinc Yellow

**Corrosion Protection Level:** Moderate

**Standard:** DIN 6926

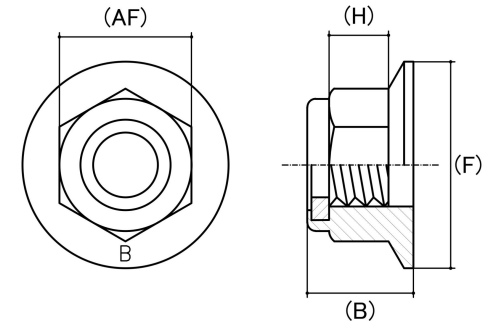

*CAD drawings shown for graphic representation only.\**

Size	Thread Pitch (mm)	Thread Type	Overall Nut Height (B) (mm)		Hex Height (H) (mm)	Flange Diameter (F) (mm)	Across Flats (AF) (mm)		Spanner Size (AF) (mm)	sku (qfind)
			Min	Max	Nom	Nom	Min	Max		
M24	2.00	Fine	29.00	29.80	15.60	45.00	35.16	36.00	36	41FLNMF24200ZY

**Disclaimer:**

Dimensional data and technical information was obtained from publicly available sources and not acquired through standard agencies. It has been completed and compiled for reference purposes only; where discrepancies are found they are subject to change without notice. Bolt & Nut Australia makes no warranties or representations regarding the accuracy and validity of the compiled information and data. Contact the relevant standard authorities for accurate and detailed information.

\* CAD drawings may not reflect diameter, thread length or overall length.

© Bolt & Nut Australia Pty Ltd. All rights reserved.

Version: 18 Mar 2024